

90P FEED

Aufsteckfräser 90° / SD.. 18
Face milling cutter 90° / SD.. 18

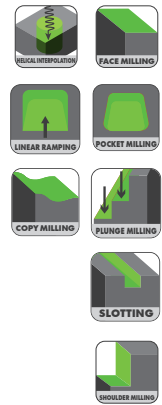
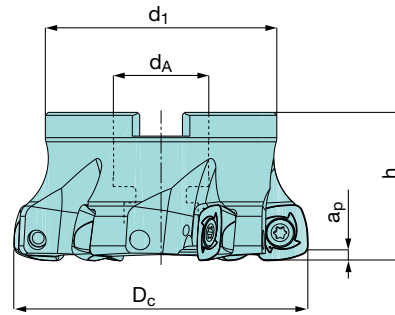

Abmessungen [mm] Dimensions [mm]						Artikelbezeichnung Item Code	Bestell-Nr. Order No	Verfüg. Availability	Ersatzteile Spare parts	
D _C	d _A	d ₁	h	ap/HF	z					
63	27	60	50	3,5	4	HMF90 SD18.063 Z04-DA27	2242300	○	Spannschraube Fastening screw HK02-71271 5001600 MA = 6Nm	Torx-Schlüssel Torque wrench T25 5000500
80	27	60	50	3,5	5	HMF90 SD18.080 Z05	2242400	●		
100	32	78	50	3,5	6	HMF90 SD18.100 Z06	2242500	●		
125	40	90	60	3,5	7	HMF90 SD18.125 Z07	2242600	●		
160	40	115	60	3,5	9	HMF90 SD18.160 Z09-NC	2242700	●		
200	60	140	65	3,5	11	HMF90 SD18.200 Z11-NC	2242800	●		

Bild & Zeichnung Image & Drawings	Artikelbezeichnung Item Code	Schneidstoffsorte Cutting materials	Bestell-Nr. Order No	Verfüg. Availability	Abmessungen [mm] Dimensions [mm]					
					l	d	s	d ₁	r	
<p>N=4</p>	HF Platten/HF inserts									
	■ SDMT 180630 TR-NRH	HAP25M	2185700	●	3,0	18,7	6	6,5	3	
	■ SDMT 180630 TR-NRH	HAP35M	2185800	●	3,0	18,7	6	6,5	3	
	■ SDMT 180630 TR-NNH	HAM35M	2185500	●	3,0	18,7	6	6,5	3	
	■ SDMT 180630 TR-NNH	HAM40M	2185600	●	3,0	18,7	6	6,5	3	
	■ SDMT 180630 TR-NFH	HAS35M	2185900	○	3,0	18,7	6	6,5	3	
	■ SDMT 180630 TR-OHH	HAH30M	2185400	○	3,0	18,7	6	6,5	3	
	■ SDMW 180630 TR-DPH	HAP35M	2188100	●	3,0	18,7	6	6,5	3	
	■ SDMW 180630 TR-DPH	HAP40M	2188200	●	3,0	18,7	6	6,5	3	
	■ SDMW 180630 TR-DKH	HAK15M	2187900	●	3,0	18,7	6	6,5	3	
	■ SDMW 180630 TR-DKH	HAK20M	2188000	●	3,0	18,7	6	6,5	3	
	■ SDMW 180630 TR-DHH	HAH30M	2187800	●	3,0	18,7	6	6,5	3	