

# 90P FEED

Aufsteckfräser 90° / SD.. 10  
Face milling cutter 90° / SD.. 10

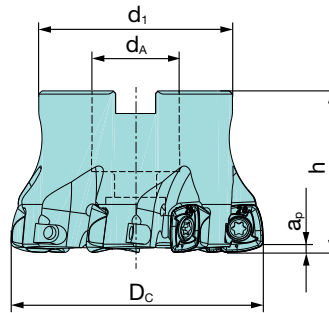

Abmessungen [mm] Dimensions [mm]							Artikelbezeichnung Item Code	Bestell-Nr. Order No	Verfüg. Availability	Ersatzteile Spare parts		
DC	dA	d1	h	ap/90	ap/HF	z						
40	16	35	40	9	1,5	4	HMF90 SD10.040 Z04	2239800	•	Spann- schraube Fastening screw HKE02- 41194 5002200 MA = 2Nm	Torx- Schlüssel Torque wrench IP9 5000900	* Differentialschraube SD10 Centre screw SD 10 5005100
40	16	35	40	9	1,5	6	HMF90 SD10.040 Z06	2239900	•			
42	16	35	40	9	1,5	5	HMF90 SD10.042 Z05	2240000	◦			
50	22	43	40	9	1,5	5	HMF90 SD10.050 Z05	2240100	•			
50	22	43	40	9	1,5	7	HMF90 SD10.050 Z07	2240200	•			
52	22	43	40	9	1,5	5	HMF90 SD10.052 Z05	2240300	•			
63	22	48	40	9	1,5	6	HMF90 SD10.063 Z06	2240400	•			
63	22	48	40	9	1,5	8	HMF90 SD10.063 Z08	2240500	•			
66	22	48	40	9	1,5	5	HMF90 SD10.066 Z05	2240600	◦			
66	27	48	40	9	1,5	8	HMF90 SD10.066 Z08-DA27	2240700	◦			
80	27	60	50	9	1,5	8	HMF90 SD10.080 Z08	2240800	•			

Aufsteckfräser 90° / SD.. 10 / INCH  
Face milling cutter 90° / SD.. 10 / INCH

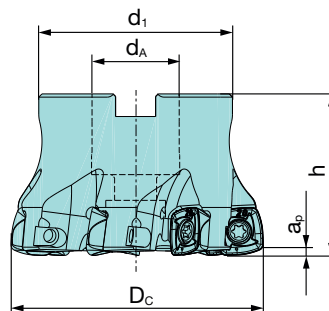

Abmessungen [INCH] Dimensions [INCH]							Artikelbezeichnung Item Code	Bestell-Nr. Order No	Verfüg. Availability	Ersatzteile Spare parts		
DC	dA	d1	h	ap/90	ap/HF	z						
2.0	0.75	1.750	1.50	0.354	0.059	5	HMFU90 SD10.2000 Z05-INCH	2252600	◦	Spann- schraube Fastening screw HKE02- 41194 5002200 MA = 2Nm	Torx- Schlüssel Torque wrench IP9 5000900	
2.0	0.75	1.750	1.50	0.354	0.059	7	HMFU90 SD10.2000 Z07-INCH	2252700	◦			
2.5	1.00	2.250	1.75	0.354	0.059	6	HMFU90 SD10.2500 Z06-INCH	2252800	◦			
2.5	1.00	2.250	1.75	0.354	0.059	8	HMFU90 SD10.2500 Z08-INCH	2252900	◦			