

# 88N FACECUT

Aufsteckfräser 88° / SN.. 12  
Face milling cutter 88° / SN.. 12

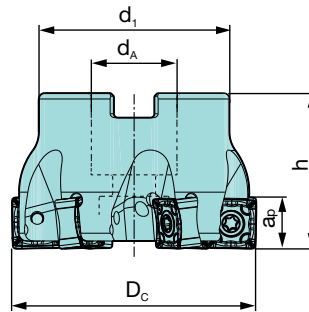

Abmessungen [mm] Dimensions [mm]						Artikelbezeichnung Item Code	Bestell-Nr. Order No	Verfüg. Availability	Ersatzteile Spare parts	
Dc	dA	d1	h	ap	z					
50	22	42	40	10	4	HMF88 SN12.050 Z04	2232000	o	Spannschraube Fastening screw HKE06-51226 5002800 MA = 5Nm	Torx- Schlüssel Torque wrench IP20 5001200
63	22	49	40	10	6	HMF88 SN12.063 Z06	2232100	o		
63	27	58	50	10	6	HMF88 SN12.063 Z06-DA27	2232200	o		
80	27	60	50	10	7	HMF88 SN12.080 Z07	2232300	o		
80	27	60	50	10	9	HMF88 SN12.080 Z09	2232400	o		
100	32	80	50	10	8	HMF88 SN12.100 Z08	2232500	o		
100	32	80	50	10	11	HMF88 SN12.100 Z11	2232600	o		
125	40	95	63	10	10	HMF88 SN12.125 Z10	2232700	o		
125	40	95	63	10	14	HMF88 SN12.125 Z14	2232800	o		
160	40	115	63	10	12	HMF88 SN12.160 Z12-NC	2232900	o		
160	40	115	63	10	18	HMF88 SN12.160 Z18-NC	2233000	o		
200	60	164	63	10	14	HMF88 SN12.200 Z14-NC	2233100	o		
200	60	164	63	10	22	HMF88 SN12.200 Z22-NC	2233200	o		
250	60	184	63	10	16	HMF88 SN12.250 Z16-NC	2233300	o		
250	60	184	63	10	24	HMF88 SN12.250 Z24-NC	2233400	o		

Bild & Zeichnung Image & Drawings	Artikelbezeichnung Item Code	Schneidstoffsorte Cutting materials	Bestell-Nr. Order No	Verfüg. Availability	Abmessungen [mm] Dimensions [mm]					
					l	d	s	d1	r	
 N = 8	■ SNMX 120608 TM-NR	HAP30M	2154500	•	12,70	12,70	5,8	5,2	0,8	
	■ SNMX 120608 TM-NR	HAP35M	2154600	•	12,70	12,70	5,8	5,2	0,8	
	■ SNMX 120608 TM-NN	HAM40M	2154400	•	12,70	12,70	6,2	5,2	0,8	
	■ SNMX 120608 TM-NK	HAK15M	2154200	•	12,70	12,70	5,8	5,2	0,8	
	■ SNMX 120608 TM-NK	HAK20M	2154300	•	12,70	12,70	5,8	5,2	0,8	
	■ SNMX 120612 TM-NR	HAP30M	2154900	•	12,70	12,70	5,8	5,2	1,2	
	■ SNMX 120612 TM-NR	HAP35M	2155000	•	12,70	12,70	5,8	5,2	1,2	
	■ SNMX 120612 TM-NK	HAK15M	2154700	•	12,70	12,70	5,8	5,2	1,2	
	■ SNMX 120612 TM-NK	HAK20M	2154800	•	12,70	12,70	5,8	5,2	1,2	