

**Aufsteckfräser 45° / XE.. 04 & RE.. 13**  
Face milling cutter 45° / XE.. 04 & RE.. 13

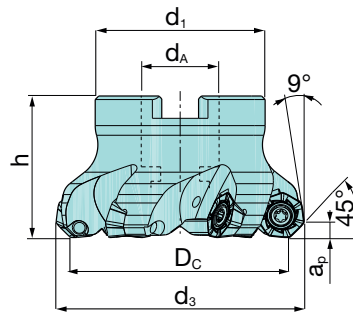

Abmessungen [mm] Dimensions [mm]							Artikelbezeichnung Item Code	Bestell-Nr. Order No	Verfüg. Availability	Ersatzteile Spare parts	
Dc	d <sub>3</sub>	d <sub>A</sub>	d <sub>1</sub>	h	a <sub>p</sub>	z				Spannschraube Fastening screw HKE02-51165 5002400 MA = 3Nm	Torx-Schlüssel Torque wrench IP15 5001100
50	57,5	22	43	40	4	5	HMF45 XE04.050 Z05	2230400	=		
52	59,5	22	43	40	4	5	HMF45 XE04.052 Z05	2230500	=		
63	70,5	22	48	40	4	5	HMF45 XE04.063 Z05	2230600	=		
63	70,5	22	48	40	4	6	HMF45 XE04.063 Z06	2230700	=		
66	73,5	22	48	40	4	6	HMF45 XE04.066 Z06	2230800	=		
80	87,5	27	60	50	4	6	HMF45 XE04.080 Z06	2230900	=		
80	87,5	27	60	50	4	8	HMF45 XE04.080 Z08	2231000	=		
100	107,5	32	78	50	4	8	HMF45 XE04.100 Z08	2231100	=		
100	107,5	32	78	50	4	10	HMF45 XE04.100 Z10	2231200	=		
125	132,5	40	90	60	4	10	HMF45 XE04.125 Z10	2231400	=		
125	132,5	40	90	60	4	12	HMF45 XE04.125 Z12	2231300	=		
160	167,5	40	115	65	4	10	HMF45 XE04.160 Z10-NC	2231500	=		
160	167,5	40	115	65	4	14	HMF45 XE04.160 Z14-NC	2231600	=		
200	207,5	60	140	65	4	16	HMF45 XE04.200 Z16-NC	2231700	=		

**Aufsteckfräser 45° / XE.. 04 & RE.. 13 / INCH**  
Face milling cutter 45° / XE.. 04 & RE.. 13 / INCH

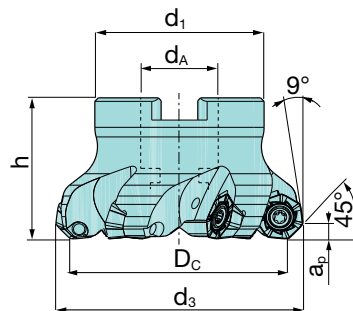

Abmessungen [INCH] Dimensions [INCH]							Artikelbezeichnung Item Code	Bestell-Nr. Order No	Verfüg. Availability	Ersatzteile Spare parts	
Dc	d <sub>3</sub>	d <sub>A</sub>	d <sub>1</sub>	h	a <sub>p</sub>	z				Spannschraube Fastening screw HKE02-51165 5002400 MA = 3Nm	Torx-Schlüssel Torque wrench IP15 5001100
2.0	2.3	0.75	1.75	1.75	0.157	5	HMFU45 XE04.2000 Z05-INCH	2249500	o		
2.5	2.8	1.00	2.00	1.75	0.157	5	HMFU45 XE04.2500 Z05-INCH	2249600	o		
2.5	2.8	1.00	2.00	1.75	0.157	6	HMFU45 XE04.2500 Z06-INCH	2249700	o		
3.0	3.3	1.25	2.75	2.00	0.157	6	HMFU45 XE04.3000 Z06-INCH	2249800	o		
3.0	3.3	1.25	2.75	2.00	0.157	8	HMFU45 XE04.3000 Z08-INCH	2249900	o		
4.0	4.3	1.50	3.50	2.00	0.157	8	HMFU45 XE04.4000 Z08-INCH	2250000	o		
4.0	4.3	1.50	3.50	2.00	0.157	10	HMFU45 XE04.4000 Z10-INCH	2250100	o		
5.0	5.3	1.50	3.75	2.50	0.157	10	HMFU45 XE04.5000 Z10-INCH	2250200	o		
5.0	5.3	1.50	3.75	2.50	0.157	12	HMFU45 XE04.5000 Z12-INCH	2250300	o		
6.0	6.3	2.00	5.00	2.50	0.157	10	HMFU45 XE04.6000 Z10-NCINCH	2250400	o		
6.0	6.3	2.00	5.00	2.50	0.157	14	HMFU45 XE04.6000 Z14-NCINCH	2250500	o		
8.0	8.3	2.50	6.00	2.50	0.157	16	HMFU45 XE04.8000 Z16-NCINCH	2250600	o		