

Aufsteckfräser 45° / SE.. 13
Face milling cutter 45° / SE.. 13

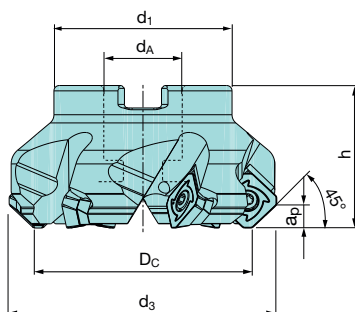
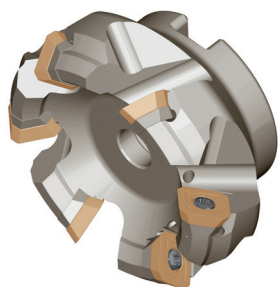

Abmessungen [mm] Dimensions [mm]							Artikelbezeichnung Item Code	Bestell-Nr. Order No	Verfüg. Availability	Ersatzteile Spare parts		
D _C	d ₃	d _A	d ₁	h	a _p	z				Spann- schraube Fastening screw HKE02- 46232 MA= 5Nm	Torx- Schlüs- sel Torque wrench IP15 5001100	Schraube SE13 Screw 5005000 Unterlegs- platte SE13 Shim 5005300
50	63	22	44	40	6	4	HMF45 SE13.050 Z04	2225600	o			
50	63	22	44	40	6	5	HMF45 SE13.050 Z05	2225700	o			
63	76	22	50	40	6	5	HMF45 SE13.063 Z05	2225800	o			
63	76	22	50	40	6	6	HMF45 SE13.063 Z06	2225900	o			
80	93	27	60	50	6	6	HMF45 SE13.080 Z06	2226000	o			
80	93	27	60	50	6	8	HMF45 SE13.080 Z08	2226100	o			
100	113	32	80	50	6	7	HMF45 SE13.100 Z07	2226200	o			
100	113	32	80	50	6	10	HMF45 SE13.100 Z10	2226300	o			
125	138	40	95	63	6	8	HMF45 SE13.125 Z08	2226400	o			
125	138	40	95	63	6	12	HMF45 SE13.125 Z12	2226500	o			
160	173	40	115	63	6	7	HMF45 SE13.160 Z07	2226600	o			
160	173	40	115	63	6	10	HMF45 SE13.160 Z10	2226700	o			
200	213	60	164	63	6	8	HMF45 SE13.200 Z08	2226800	o			
200	213	60	164	63	6	12	HMF45 SE13.200 Z12	2226900	o			
250	263	60	184	63	6	10	HMF45 SE13.250 Z10	2227000	o			
250	263	60	184	63	6	14	HMF45 SE13.250 Z14	2227100	o			
315	334	60	265	80	6	12	HMF45 SE13.315 Z12	2227200	o			
315	334	60	265	80	6	18	HMF45 SE13.315 Z18	2227300	o			