

Aufsteckfräser 45° / SN.. 12 / INCH
Face milling cutter 45° / SN.. 12 / INCH

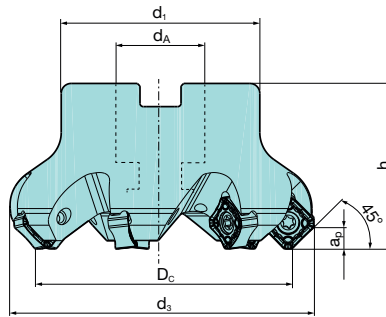

| Abmessungen [INCH] Dimensions [INCH] | | | | | | | Artikelbezeichnung Item Code | Bestell-Nr. Order No | Verfüg. Availability | Ersatzteile Spare parts | |
|---|----------------|----------------|----------------|------|----------------|----|---------------------------------|-------------------------|-------------------------|---|---|
| D _C | d ₃ | d _A | d ₁ | h | a _p | z | | | | | |
| 2.0 | 2.5 | 0.75 | 2.00 | 1.50 | 0.256 | 4 | HMFU45 SN12.2000 Z04-INCH | 2248200 | o | Spann- schraube Fastening screw HKE06- 51226 5002800 MA= 5Nm | Torx- Schlüssel Torque wrench IP20 5001200 |
| 2.0 | 2.5 | 0.75 | 2.00 | 1.50 | 0.256 | 6 | HMFU45 SN12.2000 Z06-INCH | 2248300 | o | | |
| 2.5 | 3.0 | 1.00 | 2.50 | 1.75 | 0.256 | 6 | HMFU45 SN12.2500 Z06-INCH | 2248400 | o | | |
| 2.5 | 3.0 | 1.00 | 2.50 | 1.75 | 0.256 | 8 | HMFU45 SN12.2500 Z08-INCH | 2248500 | o | | |
| 3.0 | 3.5 | 1.00 | 2.50 | 1.75 | 0.256 | 7 | HMFU45 SN12.3000 Z07-INCH | 2248600 | o | | |
| 3.0 | 3.5 | 1.00 | 2.50 | 1.75 | 0.256 | 10 | HMFU45 SN12.3000 Z10-INCH | 2248700 | o | | |
| 4.0 | 4.5 | 1.50 | 3.75 | 2.25 | 0.256 | 8 | HMFU45 SN12.4000 Z08-INCH | 2248800 | o | | |
| 4.0 | 4.5 | 1.50 | 3.75 | 2.25 | 0.256 | 12 | HMFU45 SN12.4000 Z12-INCH | 2248900 | o | | |
| 5.0 | 5.5 | 1.50 | 3.75 | 2.50 | 0.256 | 10 | HMFU45 SN12.5000 Z10-INCH | 2249000 | o | | |
| 5.0 | 5.5 | 1.50 | 3.75 | 2.50 | 0.256 | 16 | HMFU45 SN12.5000 Z16-INCH | 2249100 | o | | |
| 6.0 | 6.5 | 2.00 | 5.00 | 2.50 | 0.256 | 12 | HMFU45 SN12.6000 Z12-NCINCH | 2249200 | o | | |
| 6.0 | 6.5 | 2.00 | 5.00 | 2.50 | 0.256 | 20 | HMFU45 SN12.6000 Z20-NCINCH | 2249300 | o | | |
| 8.0 | 8.5 | 2.50 | 6.00 | 2.50 | 0.256 | 18 | HMFU45 SN12.8000 Z18-NCINCH | 2249400 | o | | |
| 10 | 10.5 | 2.50 | 7.50 | 2.50 | 0.256 | 20 | HMFU45 SN12.10000 Z20-NCINCH | 2248100 | o | | |

| Bild & Zeichnung Image & Drawings | Artikelbezeichnung Item Code | Schneidstoffsorte Cutting materials | Bestell-Nr. Order No | Verfüg. Availability | Abmessungen [mm] Dimensions [mm] | | | | |
|--------------------------------------|---------------------------------|--|-------------------------|-------------------------|-------------------------------------|-------|-----|----------------|---|
| | | | | | l | d | s | d ₁ | r |
| <p>N = 2</p> | ■ SNEX 1206-SW | HAM35M | 2153100 | • | 12,70 | 12,70 | 5,8 | 5,2 | - |
| | ■ SNMX 1206 ANSN-NR | HAP20M | 2153600 | • | 12,70 | 12,70 | 5,8 | 5,2 | - |
| | ■ SNMX 1206 ANSN-NR | HAP25M | 2153700 | • | 12,70 | 12,70 | 5,8 | 5,2 | - |
| | ■ SNMX 1206 ANSN-NR | HAP30M | 2153800 | • | 12,70 | 12,70 | 5,8 | 5,2 | - |
| | ■ SNMX 1206 ANSN-NR | HAP35M | 2153900 | • | 12,70 | 12,70 | 5,8 | 5,2 | - |
| | ■ SNMX 1206 ANSN-NN | HAM35M | 2153400 | • | 12,70 | 12,70 | 6,2 | 5,2 | - |
| | ■ SNMX 1206 ANSN-NN | HAM40M | 2153500 | • | 12,70 | 12,70 | 6,2 | 5,2 | - |
| | ■ SNMX 1206 ANSN-NK | HAK15M | 2153200 | • | 12,70 | 12,70 | 5,8 | 5,2 | - |
| | ■ SNMX 1206 ANSN-NK | HAK20M | 2153300 | • | 12,70 | 12,70 | 5,8 | 5,2 | - |
| | ■ SNHX 1206 ANFN-NP | HANI10M | 2203400 | • | 12,7 | 12,7 | 6,2 | 5,2 | - |
| ■ SNHX 1206 ANFN-NP | HXN10M | 2203500 | • | 12,7 | 12,7 | 6,2 | 5,2 | - | |
| ■ SNMX 1206 ANSN-NU | HAS35M | 2154000 | • | 12,70 | 12,70 | 6,2 | 5,2 | - | |
| ■ SNMX 1206 ANSN-NU | HAS40M | 2154100 | o | 12,70 | 12,70 | 6,2 | 5,2 | - | |