

Schaftfräser 45° / XE.. 04 & RE.. 13
End milling cutter 45° / XE.. 04 & RE.. 13

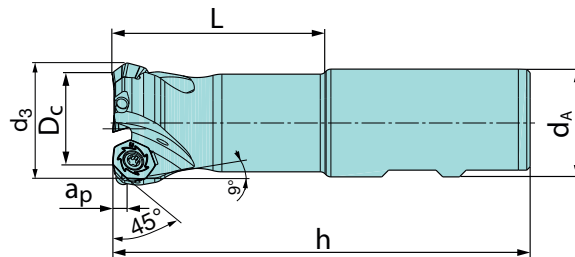

Abmessungen [mm] Dimensions [mm]							Schaft Shank	Artikelbezeichnung Item Code	Bestell-Nr. Order No	Verfüg. Availability	Ersatzteile Spare parts	
Dc	d3	dA	h	L	ap	z						
25	32,5	25	106	50	4	2	SW	HME45 XE04.025 Z02	2205000	=	Spannschraube Fastening screw HKE02-51193 5002500 MA = 3Nm	Torx- Schlüssel Torque wrench IP15 5001100
32	39,5	32	124	64	4	3	SW	HME45 XE04.032 Z03	2205100	=		
36	43,5	32	124	64	4	3	SW	HME45 XE04.036 Z03	2205200	=	Spannschraube Fastening screw HKE02-51165 5002400 MA = 3Nm	Torx- Schlüssel Torque wrench IP15 5001100
40	47,5	32	130	65	4	4	SW	HME45 XE04.040 Z04	2205300	=		

Einschraubfräser 45° / XE.. 04 & RE.. 13
Screw on type 45° / XE.. 04 & RE.. 13

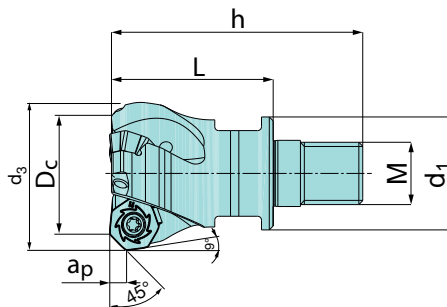

Abmessungen [mm] Dimensions [mm]							Artikelbezeichnung Item Code	Bestell-Nr. Order No	Verfüg. Availability	Ersatzteile Spare parts		
Dc	d3	d1	L	h	ap	M						z
25	32,5	21	32	54	4	12	2	HMS45 XE04.025 Z02-M12	2255800	=	Spannschraube Fastening screw HKE02-51193 5002500 MA = 3Nm	Torx- Schlüssel Torque wrench IP15 5001100
32	39,5	29	42	65	4	16	3	HMS45 XE04.032 Z03-M16	2255900	=		
40	47,5	29	43	66	4	16	4	HMS45 XE04.040 Z04-M16	2256000	=	Spannschraube Fixationscrew HKE02-51165 5002400 MA = 3Nm	